

1. PHYSICAL DIMENSION(UNIT: m/m):

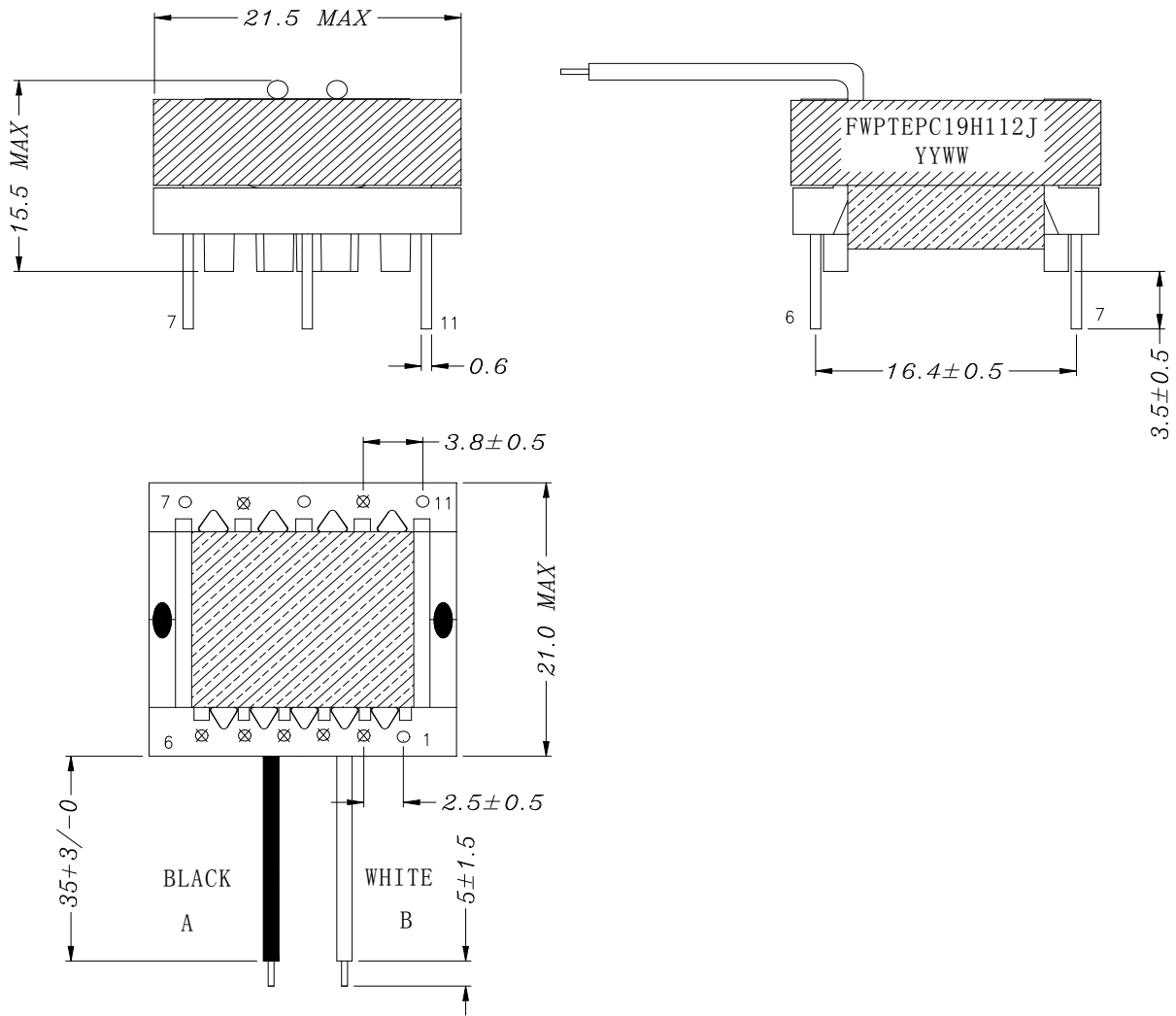

※ DIMENSIONS WITHOUT TOLERANCE ARE APPROX
 ※ DIMENSION DOES NOT INCLUDE SOLDER USED ON COILS

LEAD FREE

NOTE: PIN2,3,4,5,6,8,10 cut off

DIM	A	B	C	D	E	F	G	H						
SPEC														
						DESCRIPTION			TRANSFORMER					
						Customer P/N								
						FERRIWO P/N			FWPTEPC19H112J					
SPEC. NO.	PS-1001-123				PREPARED			APPROVED						

2.WINDING TABLE:

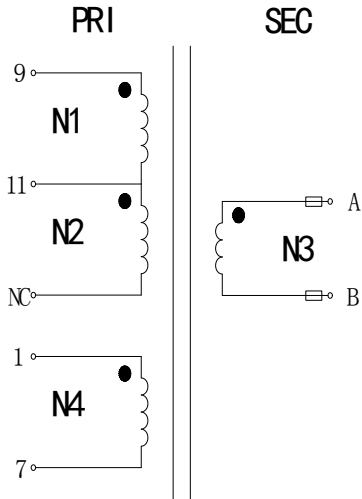

3.WINDING:

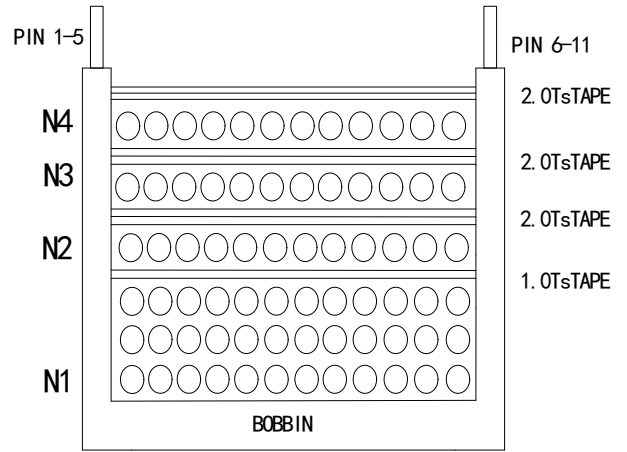

4.WINDING TABLE:

Winding NO.	Margin Tape	PIN	Wire &Wire Copper	Turns	Winding Type	Tape Layer	Tube
N1	0	9~11			Compact	1.0	0
N2	0	11~NC			Compact	2.0	0
N3	0	A~B			Compact	2.0	0
N4	0	1~7			Compact	2.0	0

NOTE:

1. Products should be vacuum varnish
 - *VARNISH RATIO: 1:1
 - *VACUUM TIME: 15~20minutes
 - *BAKED TEMPERATURE : 120°C±10°C , 1~1.5hours

LEAD FREE

	DESCRIPTION	TRANSFORMER			
	Customer P/N				
	FERRIWO P/N	FWPTEPC19H112J			
SPEC. NO.	PS-1001-123	PREPARED		APPROVED	



SPECIFICATION

5. ELECTRONICAL CHARACTERISTIC:

TEST CONDITION : TEMPERATURE AT 25°C
HUMIDITY AT 65 ±5% RH

TEST ITEM	TEST CONDITION	RESULT
INDUCTANCE CH-3250	@1.0KHz,1.0V (11~9)	1.15mH±10%
HI-POT TEST CH-9052	@ 2mA 3SEC (AC)	P<->S 4.0 KV; COIL<-> CORE 1.0KV;

LEAD FREE

		DESCRIPTION	TRANSFORMER		
		Customer P/N			
		FERRIWO P/N	FWPTEPC19H112J		
SPEC. NO.	PS-1001-123	PREPARED		APPROVED	

SPECIFICATION

6. MATERIAL LIST :

ITEM		MATERIAL	SUPPLIER OR MANUFACTURER	TEMPRATING
1	CORE	FW40 OR EQUIVALENT	HAINING FERRIWO ELECTRONICS CO., LTD.	
2	BOBBIN	PHENOLIC OR EQUIVALENT	SUMITOMO BAKELITE CO., LTD. UL NO E41429	150℃
3	WIRE	2UEW	PACIFIC ELECTRIC WIRE&CABLE(SHENZHEN) CO. LTD UL NO E84081	155℃
4	KAPTON TAPE	PF-301	YAHUA STICKING TAPE CO.,LTD UL NO E165111	180℃
5	TRIPLE WIRE	TRIPLE. INSULATION. WIRE TRW(F)	GREAT LEOFLON INDUSTRIAL CO.,LTD UL NO E211989	155℃
6	TUBE	TEFLON TUBE	GREAT HOLDING INDUSTRIAL CO.,LTD UL NO E156256	200℃
7	FLUX	TF9100	LINAN GUITONG CHEMICAL TECHNICAL CO.,LTD	
8	VARNISH	T-4260A	WUJIANG TAIHU INSULATING MATERIAL CO., LTD UL NO E228349	130℃
9	EPOXY	E-500 (BLACK)	SUZHOU EATTO ELECTRONIC MATERIAL CO.,LTD UL NO E218090	130℃
10	TIN	Sn99.3Cu0.7	HAINING ZHUCHANG METAL FOIL CO;LTD	

LEAD FREE



DESCRIPTION

TRANSFORMER

Customer P/N

FERRIWO P/N

FWPTEPC19H112J

SPEC. NO.

PS-1001-123

PREPARED



APPROVED

