

SPECIFICATION

1. PHYSICAL DIMENSION(UNIT: m/m):

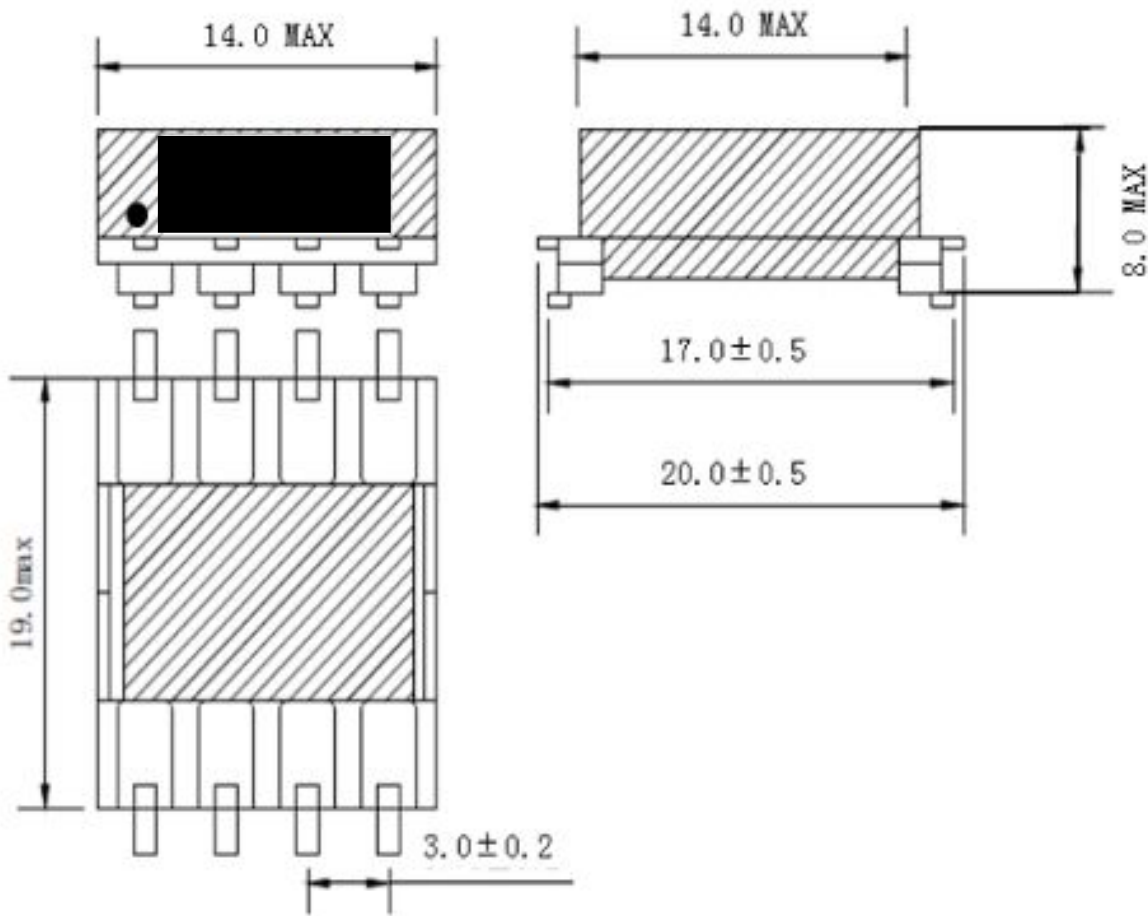

- ※ DIMENSIONS WITHOUT TOLERANCE ARE APPROX
- ※ DIMENSION DOES NOT INCLUDE SOLDER USED ON COILS

LEAD FREE

DIM	A	B	C	D	E	F	G	H				
SPEC												
						DESCRIPTION		TRANSFORMER				
						Customer P/N						
						FERRIWO P/N		FWPTEFD12SMD251M				
SPEC. NO.	PS-1001-130				PREPARED			APPROVED				

SPECIFICATION

2.WINDING TABLE:

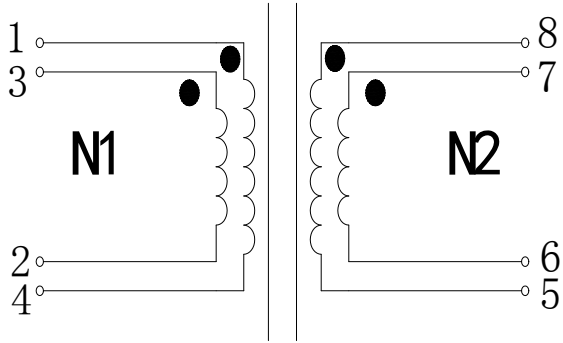

3.WINDING:

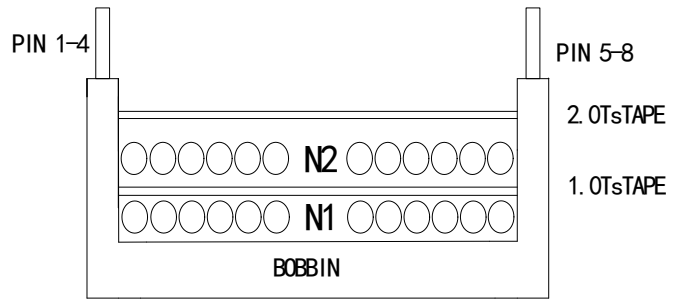

4.WINDING TABLE:

Winding NO.	Margin Tape	PIN	Wire & Wire Copper	Turns	Winding Type	Tape Layer	Tube
N1	0	1,3~2,4			Compact	1.0	
					Compact		
N2	0	6,8~5,7			Compact	2.0	
					Compact		

NOTE:

1. Products should be vacuum varnish
 - *VARNISH RATIO: 1:1
 - *VACUUM TIME: 15~20minutes
 - *BAKED TEMPERATURE : 120°C±10°C, 1~1.5hours
2. Use 0.05t*12.7mm copper foil around the coil with 1 turn after varnish

LEAD FREE

	DESCRIPTION	TRANSFORMER	
	Customer P/N		
	FERRIWO P/N	FWPTEFD12SMD251M	
SPEC. NO.	PS-1001-130	PREPARED	APPROVED

SPECIFICATION

5. ELECTRONICAL CHARACTERISTIC:

TEST CONDITION : TEMPERATURE AT 25°C
HUMIDITY AT 65 ±5% RH

TEST ITEM	TEST CONDITION	RESULT
INDUCTANCE CH-3250	@1.0KHz,1.0V (1~2)=(3~4) (6~5)=(8~7)	137.2uH±25% 252.7uH±25%
D.C.R CH-502	TBD	TBD
HI-POT TEST CH-9052	@ 2mA 3SEC	N1<->N2 0.5 KV;

LEAD FREE

	DESCRIPTION	TRANSFORMER			
	Customer P/N				
	FERRIWO P/N	FWPTEFD12SMD251M			
SPEC. NO.	PS-1001-130	PREPARED		APPROVED	

SPECIFICATION

6. MATERIAL LIST :

ITEM	MATERIAL	SUPPLIER OR MANUFACTURER	TEMPRATING	
1	CORE	FW40 OR EQUIVALENT	HAINING FERRIWO ELECTRONICS CO., LTD.	
2	BOBBIN	PHENOLIC OR EQUIVALENT	SUMITOMO BAKELITE CO., LTD. UL NO E41429	150°C
3	WIRE	2UEW	PACIFIC ELECTRIC WIRE&CABLE(SHENZHEN) CO. LTD UL NO E84081	155°C
4	TAPE	CT280	YAHUA STICKING TAPE CO.,LTD UL NO E165111	130°C
5	FLUX	TF9100	LINAN GUITONG CHEMICAL TECHNICAL CO.,LTD	
6	VARNISH	T-4260A	WUJIANG TAIHU INSULATING MATERIAL CO., LTD UL NO E228349	130°C
7	TIN	Sn99.3Cu0.7	HAINING ZHUCHANG METAL FOIL CO;LTD	

LEAD FREE



DESCRIPTION

TRANSFORMER

Customer P/N

FERRIWO P/N

FWPTEFD12SMD251M

SPEC. NO.

PS-1001-130

PREPARED

APPROVED