

# SPECIFICATION

## 1. PHYSICAL DIMENSION(UNIT: m/m):

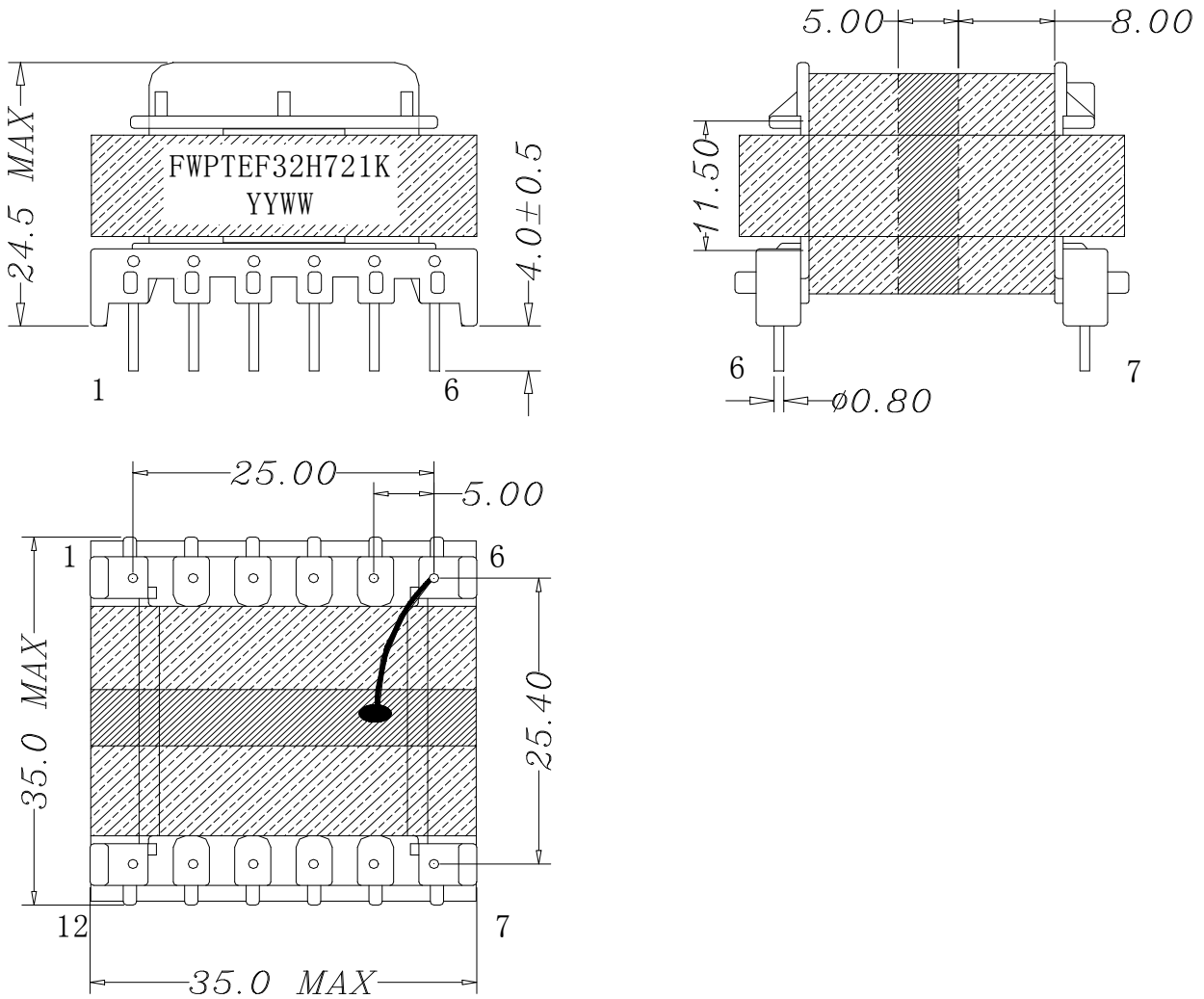

※DIMENSIONS WITHOUT TOLERANCE ARE APPROX  
 ※DIMENSION DOES NOT INCLUDE SOLDER USED ONCOILS

**LEAD FREE**

DIM	A	B	C	D	E	F	G	H				
SPEC												
						DESCRIPTION			TRANSFORMER			
						Customer P/N						
						FERRIWO P/N			FWPT32H721K			
SPEC. NO.	PS-1001-122				PREPARED			APPROVED				

# SPECIFICATION

## 2.WINDING TABLE:

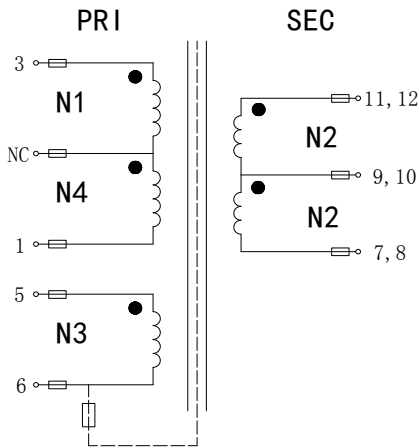

## 3.WINDING:

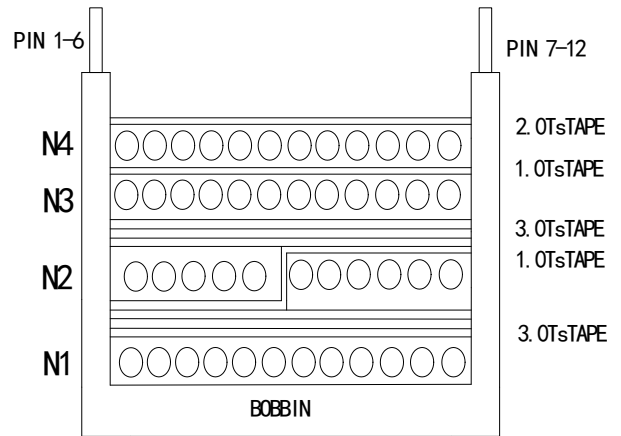

## 4.WINDING TABLE:

Winding NO.	Margin Tape	PIN	Wire & Wire Copper	Turns	Winding Type	Tape Layer	Tube
N1	0	3~NC			Dispersed	3.0	F=S≈10mm
N2	0	9,10~7,8			Compact	1.0	F=S≈10mm
		11,12~9,10			Compact	3.0	
N3	0	5~6			Dispersed	1.0	F=S≈10mm
N4	0	NV~1			Dispersed	2.0	F=S≈10mm

### NOTE:

- Products should be vacuum varnish
  - \*VARNISH RATIO: 1:1
  - \*VACUUM TIME: 15~20minutes
  - \*BAKED TEMPERATURE : 120°C±10°C, 1~1.5hours
- Use 0.25t\*5.0mm copper foil around the coil and connet to pin6 with triple wire TRW-B-0.20mm (see below picture1)
- All the cores need to use 2turns mylar tape(see below picture2)



1

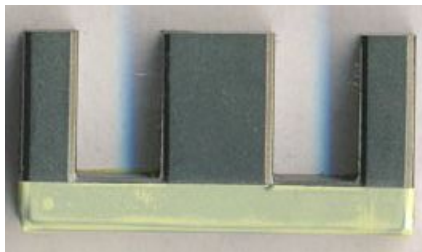

2

**LEAD FREE**



DESCRIPTION	TRANSFORMER
Customer P/N	
FERRIWO P/N	FWPTEF32H721K

SPEC. NO.	PS-1001-122	PREPARED		APPROVED	
-----------	-------------	----------	--	----------	--

# SPECIFICATION

## 5. ELECTRONICAL CHARACTERISTIC:

TEST CONDITION : TEMPERATURE AT 25°C  
HUMIDITY AT 65 ±5% RH

TEST ITEM	TEST CONDITION	RESULT
INDUCTANCE CH-3250	@1.0KHz,1.0V (1~3)	724uH±10%
HI-POT TEST CH-9052	@ 2mA 3SEC (AC)	P<->S 4.2 KV; N1,N2,N3<-> CORE 1.0KV;

**LEAD FREE**



DESCRIPTION	TRANSFORMER
Customer P/N	
FERRIWO P/N	FWPTEF32H721K

SPEC. NO.	PS-1001-122	PREPARED		APPROVED	
-----------	-------------	----------	--	----------	--

# SPECIFICATION

## 6. MATERIAL LIST :

ITEM	MATERIAL	SUPPLIER OR MANUFACTURER	TEMPRATING	
1	CORE	FW40 OR EQUIVALENT	HAINING FERRIWO ELECTRONICS CO., LTD.	
2	BOBBIN	PHENOLIC OR EQUIVALENT	SUMITOMO BAKELITE CO., LTD. UL NO E41429	150°C
3	WIRE	2UEW	PACIFIC ELECTRIC WIRE&CABLE(SHENZHEN) CO. LTD UL NO E84081	155°C
4	COPPER FOIL	0.25t*5.0mm	YAHUA STICKING TAPE CO.,LTD	
5	TAPE	CT280	YAHUA STICKING TAPE CO.,LTD UL NO E165111	130°C
6	TRIPLE WIRE	TRIPLE. INSULATION. WIRE TRW(B)	GREAT LEOFLON INDUSTRIAL CO.,LTD UL NO E211989	130°C
7	TUBE	TEFLON TUBE	GREAT HOLDING INDUSTRIAL CO.,LTD UL NO E156256	200°C
8	FLUX	TF9100	LINAN GUITONG CHEMICAL TECHNICAL CO.,LTD	
9	VARNISH	T-4260A	WUJIANG TAIHU INSULATING MATERIAL CO., LTD UL NO E228349	130°C
10	EPOXY	E-500 (BLACK)	SUZHOU EATTO ELECTRONIC MATERIAL CO.,LTD UL NO E218090	130°C
11	TIN	Sn99.3Cu0.7	HAINING ZHUCHANG METAL FOIL CO;LTD	

**LEAD FREE**



DESCRIPTION

TRANSFORMER

Customer P/N

FERRIWO P/N

FWPTEF32H721K

SPEC. NO.

PS-1001-122

PREPARED



APPROVED



