

SPECIFICATION

1. PHYSICAL DIMENSION(UNIT: m/m):

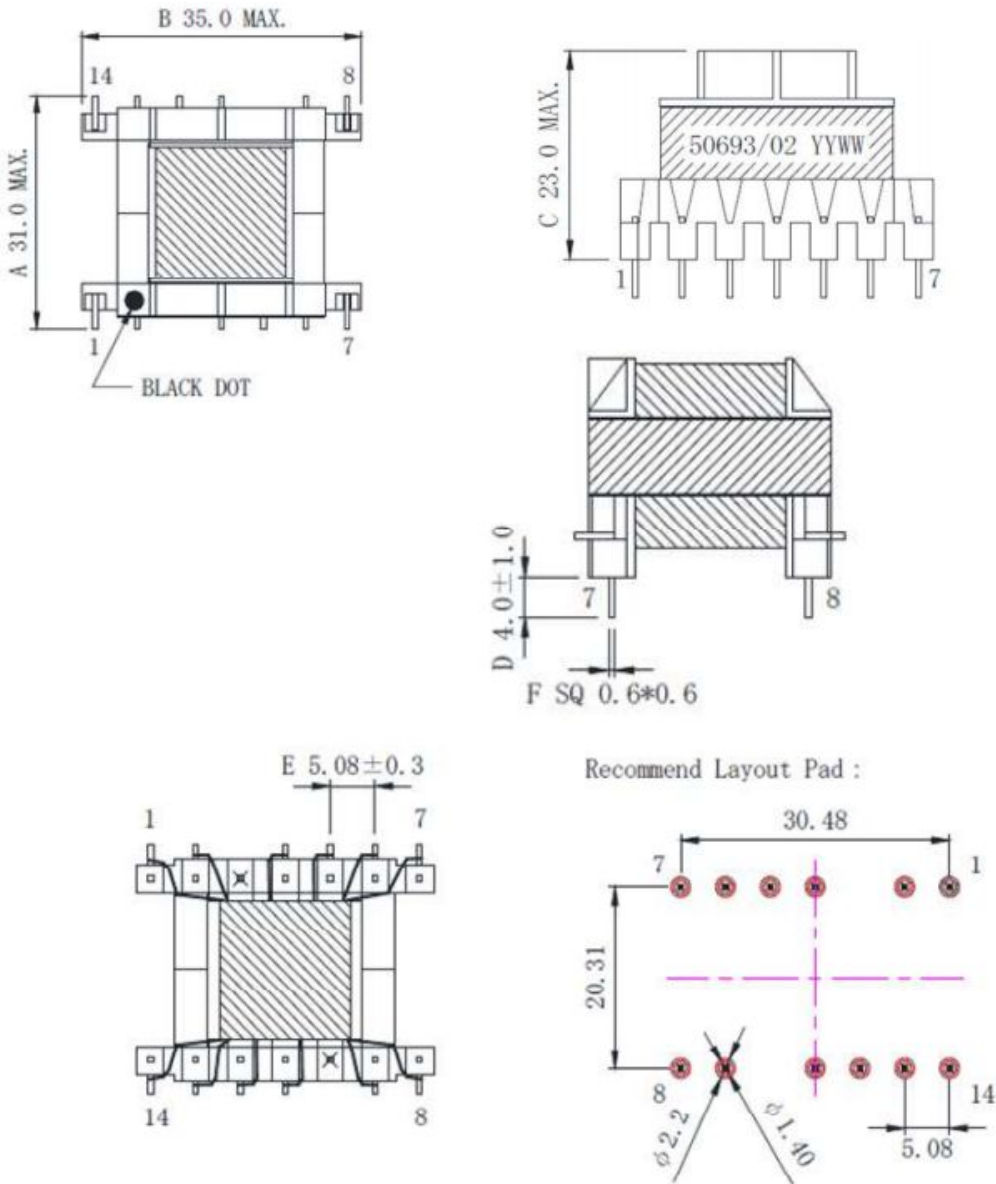

- ※ DIMENSIONS WITHOUT TOLERANCE ARE APPROX
- ※ DIMENSION DOES NOT INCLUDE SOLDER USED ON COILS

LEAD FREE

*Pin3,10 cut off.

DIM	A	B	C	D	E	F	G	H				
SPEC												
							DESCRIPTION		TRANSFORMER			
							Customer P/N					
							FERRIWO P/N		FWPTEF25H711K			
SPEC. NO.	PS-1001-131				PREPARED			APPROVED				

2.WINDING TABLE:

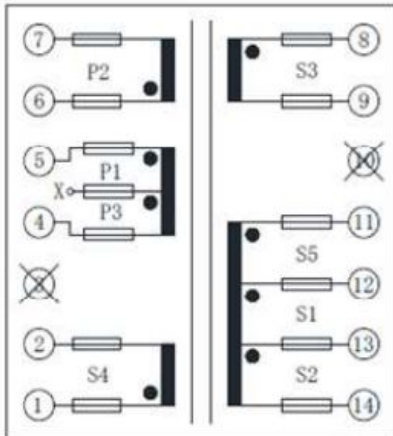

3.WINDING:

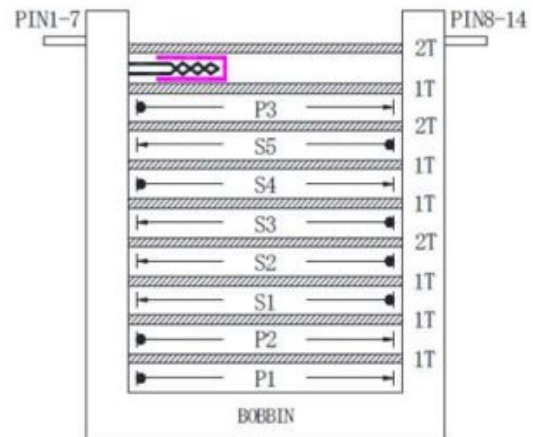

4.WINDING TABLE:

Winding NO.	Margin Tape	PIN	Wire & Wire Copper	Turns	Winding Type	Tape Layer	Tube
P1	0	5~X			Compact	1	F=S≈10mm
P2	0	6~7			Dispersed	1	F=S≈10mm
S1	0	12~13			Dispersed	1	F=S≈10mm
S2	0	13~14			Dispersed	2	F=S≈10mm
S3	0	8~9			Compact	1	F=S≈10mm
S4	0	1~2			Dispersed	1	F=S≈10mm
S5	0	11~12			Dispersed	2	F=S≈10mm
P3	0	X~4			Compact	1	F=S≈10mm
						2	

NOTE:

1. Products should be vacuum varnish
 - *VARNISH RATIO: 1:1
 - *VACUUM TIME: 15~20minutes
 - *BAKED TEMPERATURE : 120°C±10°C, 1~1.5hours

LEAD FREE

DESCRIPTION	TRANSFORMER
Customer P/N	
FERRIWO P/N	FWPTEF25H711K

SPEC. NO.	PS-1001-131	PREPARED	APPROVED
-----------	-------------	----------	----------

SPECIFICATION

4/5

5. ELECTRONICAL CHARACTERISTIC:

TEST CONDITION : TEMPERATURE AT 25°C

HUMIDITY AT 65 ±5% RH

TEST ITEM	TEST CONDITION	RESULT
INDUCTANCE CH-3250	@100.0KHz,0.25V (5~4)	714uH±10%
LEAKAGE INDUCTANCE CH-3250	@100.0KHz,0.25V (5~4)	15.0μH MAX SHORT OTHER PINS
HI-POT TEST CH-9052	@ 2mA 3SEC	P<->S 3.0 KV; COIL<->CORE 1.0 KV;

LEAD FREE



DESCRIPTION

TRANSFORMER

Customer P/N

FERRIWO P/N

FWPTEF25H711K

SPEC. NO.

PS-1001-131

PREPARED

APPROVED

SPECIFICATION

6. MATERIAL LIST :

ITEM		MATERIAL	SUPPLIER OR MANUFACTURER	TEMPRATING
1	CORE	FW40 OR EQUIVALENT	HAINING FERRIWO ELECTRONICS CO., LTD.	
2	BOBBIN	PHENOLIC OR EQUIVALENT	SUMITOMO BAKELITE CO., LTD. UL NO E41429	150°C
3	WIRE	2UEW	PACIFIC ELECTRIC WIRE&CABLE(SHENZHEN) CO. LTD UL NO E84081	155°C
4	TRIPLE WIRE	TRIPLE. INSULATION. WIRE TRW(B)	GREAT LEOFLON INDUSTRIAL CO.,LTD UL NO E211989	130°C
5	TAPE	CT280	YAHUA STICKING TAPE CO.,LTD UL NO E165111	130°C
6	PROTECT TAPE	WF-2902	YAHUA STICKING TAPE CO.,LTD UL NO E324093	130°C
7	TUBE	TEFLON TUBE	GREAT HOLDING INDUSTRIAL CO.,LTD UL NO E156256	200°C
8	FLUX	TF9100	LINAN GUITONG CHEMICAL TECHNICAL CO.,LTD	
9	VARNISH	T-4260A	WUJIANG TAIHU INSULATING MATERIAL CO., LTD UL NO E228349	130°C
10	TIN	Sn99.3Cu0.7	HAINING ZHUCHANG METAL FOIL CO;LTD	

LEAD FREE



DESCRIPTION

TRANSFORMER

Customer P/N

FERRIWO P/N

FWPTEF25H711K

SPEC. NO.

PS-1001-131

PREPARED

APPROVED