

SPECIFICATION

1. PHYSICAL DIMENSION(UNIT: m/m):

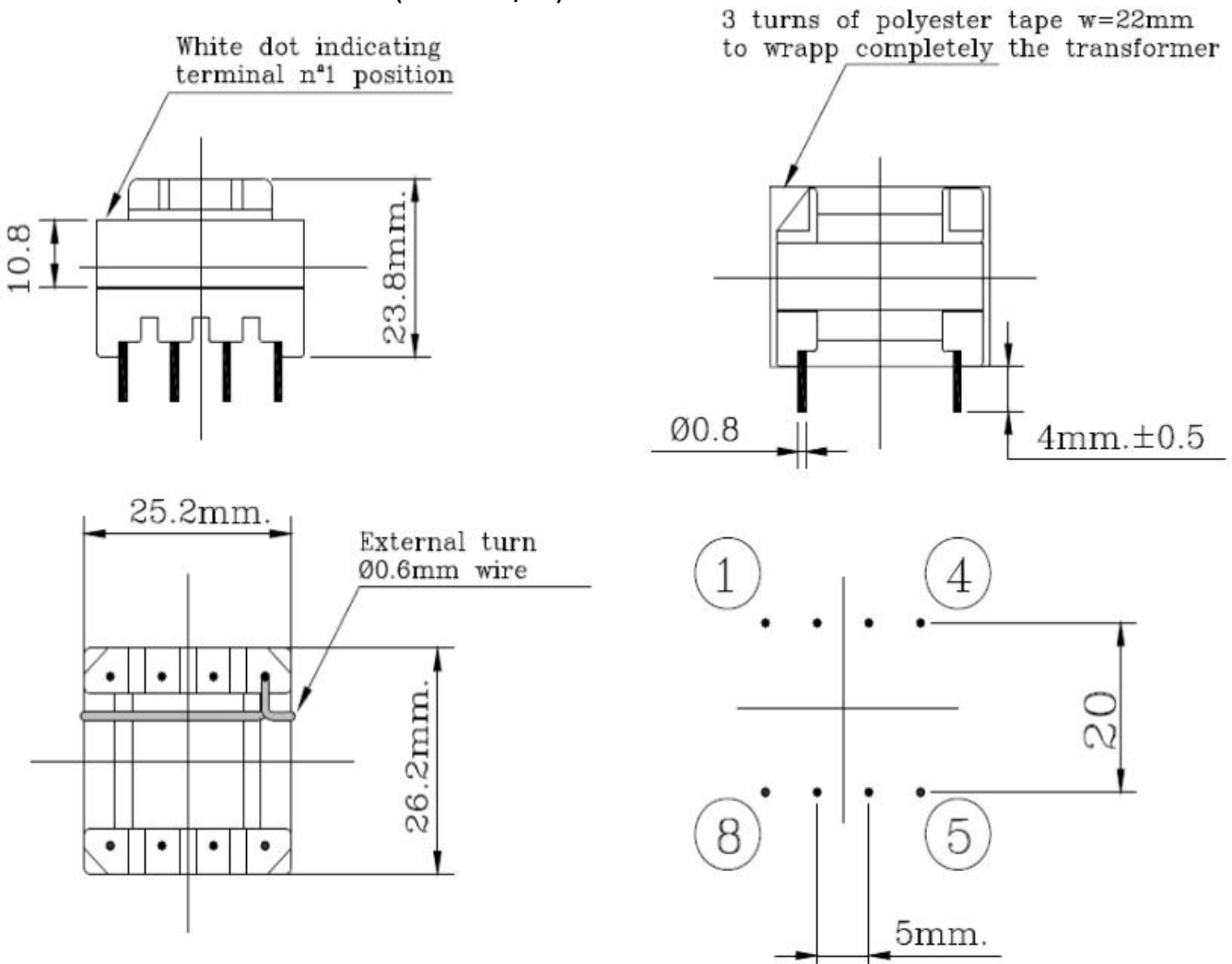

※ DIMENSIONS WITHOUT TOLERANCE ARE APPROX
 ※ DIMENSION DOES NOT INCLUDE SOLDER USED ON COILS

LEAD FREE

*Samples printing HR TC-2093-A
YYWW

DIM	A	B	C	D	E	F	G	H				
SPEC												

	DESCRIPTION	TRANSFORMER
	Customer P/N	
	FERRIWO P/N	FWPTEF25H641K

SPEC. NO.	PS-1001-048	PREPARED		APPROVED	
-----------	-------------	----------	--	----------	--

SPECIFICATION

2.WINDING TABLE:

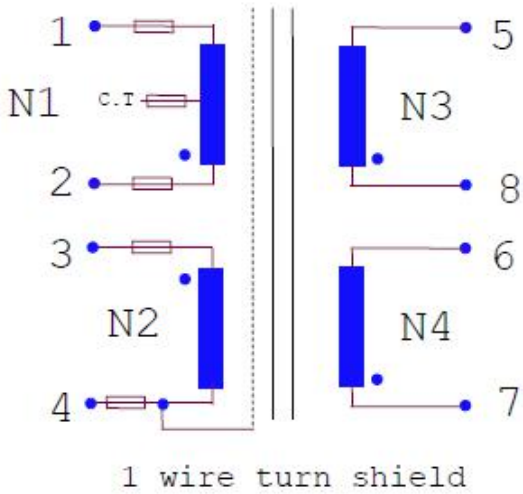

3.WINDING:

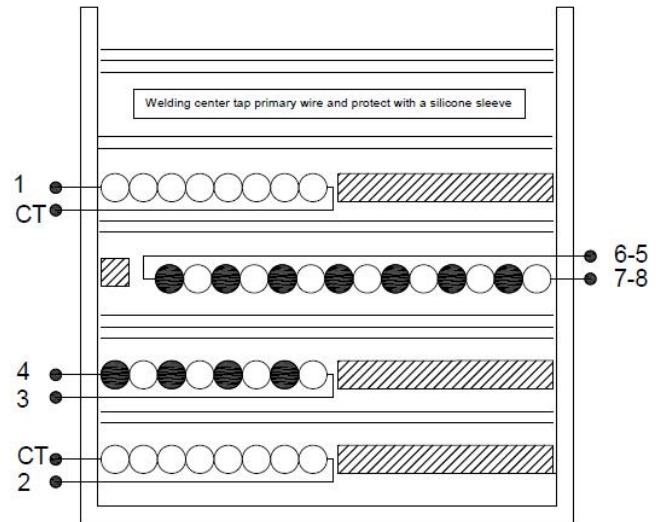

4.WINDING TABLE:

Winding NO.	Margin Tape	PIN	Wire &Wire Copper	Turns	Winding Type	Tape Layer	Tube
N1	6.0mm	2~CT			Compact	1	F≈10mm
N2	1.0mm	3~4			Compact	3	F=S≈10mm
N3	1.0mm	8~5 7~6			Compact	2	F=S≈10mm
N4	6.0mm	CT~1			Compact	2	F=S≈10mm

NOTE:

- Products should be vacuum varnish
 - *VARNISH RATIO: 1:1
 - *VACUUM TIME: 15~20minutes
 - *BAKED TEMPERATURE : 120°C±10°C, 1~1.5hours

LEAD FREE

DESCRIPTION

TRANSFORMER

Customer P/N

FERRIWO P/N

FWPTEF25H641K

SPEC. NO.

PS-1001-048

PREPARED



APPROVED





SPECIFICATION

5. ELECTRONICAL CHARACTERISTIC:

TEST CONDITION : TEMPERATURE AT 25 °C
HUMIDITY AT 65 ±5% RH

TEST ITEM	TEST CONDITION	RESULT
INDUCTANCE CH-3250	@1.0KHz,0.25V (1~2) (3~4) (5~8)=(6~7)	640uH±10% 24.5uH 24.7uH
LEAKAGE INDUCTANCE CH-3250	@100KHz,0.25V (1~2)	TBD SHORT OTHER PINS
D.C.R CH-502	(1~2) (3~4) (5~8)=(6~7)	995mΩ 43mΩ 45mΩ
HI-POT TEST CH-9052	@ 0.5mA 3.0SEC (AC)	P<->S 3.55 KV; P、S<-> CORE 1.0KV;

LEAD FREE

	DESCRIPTION	TRANSFORMER			
	Customer P/N				
	FERRIWO P/N	FWPTEF25H641K			
SPEC. NO.	PS-1001-048	PREPARED		APPROVED	

SPECIFICATION

6. MATERIAL LIST :

ITEM	MATERIAL	SUPPLIER OR MANUFACTURER	TEMPRATING	
1	CORE	FW40 OR EQUIVALENT	HAINING FERRIWO ELECTRONICS CO., LTD.	
2	BOBBIN	PHENOLIC OR EQUIVALENT	SUMITOMO BAKELITE CO., LTD. UL NO E41429	150 °C
3	WIRE	2UEW-F	PACIFIC ELECTRIC WIRE&CABLE(SHENZHEN) CO. LTD UL NO E84081	155 °C
4	TRIPLE WIRE	TRIPLE. INSULATION. WIRE TRW(B)	GREAT LEOFLON INDUSTRIAL CO.,LTD UL NO E211989	130 °C
5	TAPE	CT280	YAHUA STICKING TAPE CO.,LTD UL NO E165111	130 °C
6	MARGIN TAPE	WF-2902	YAHUA STICKING TAPE CO.,LTD UL NO E324093	130 °C
7	VARNISH	T-4260A	WUJIANG TAIHU INSULATING MATERIAL CO., LTD UL NO E228349	130 °C
8	FLUX	TF9100	LINAN GUITONG CHEMICAL TECHNICAL CO.,LTD	
9	TIN	Sn99.3Cu0.7	HAINING ZHUCHANG METAL FOIL CO;LTD	
10	EPOXY	E-500 (BLACK)	SUZHOU EATTO ELECTRONIC MATERIAL CO.,LTD UL NO E218090	130 °C
11	TUBE	TEFLON TUBE	GREAT HOLDING INDUSTRIAL CO.,LTD UL NO E156256	200 °C

LEAD FREE



DESCRIPTION

TRANSFORMER

Customer P/N

FERRIWO P/N

FWPTEF25H641K

SPEC. NO.

PS-1001-048

PREPARED



APPROVED

