

SPECIFICATION

1. PHYSICAL DIMENSION(UNIT: m/m):

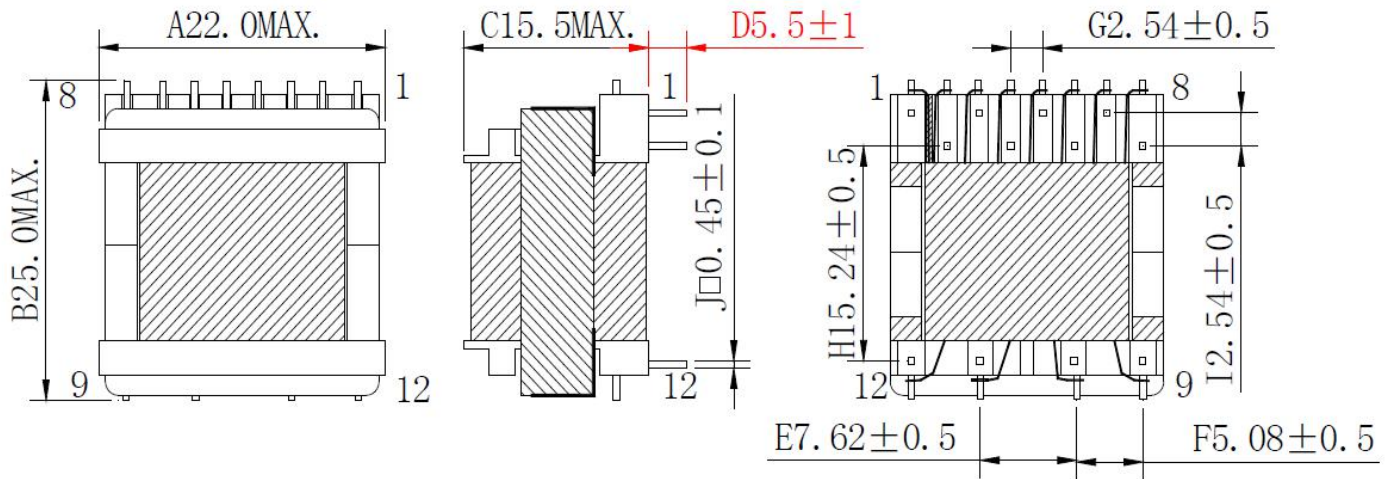

- ※ DIMENSIONS WITHOUT TOLERANCE ARE APPROX
- ※ DIMENSION DOES NOT INCLUDE SOLDER USED ON COILS

LEAD FREE

*The cores need to use the protective tape near the pins side.

*The colour of the tape which around the cores is blue.

DIM	A	B	C	D	E	F	G	H	I	J	K	L
SPEC												
							DESCRIPTION		TRANSFORMER			
							Customer P/N					
							FERRIWO P/N		FWPTEF20H421K-1			
SPEC. NO.	PS-1001-058				PREPARED			APPROVED				

2. WINDING TABLE:

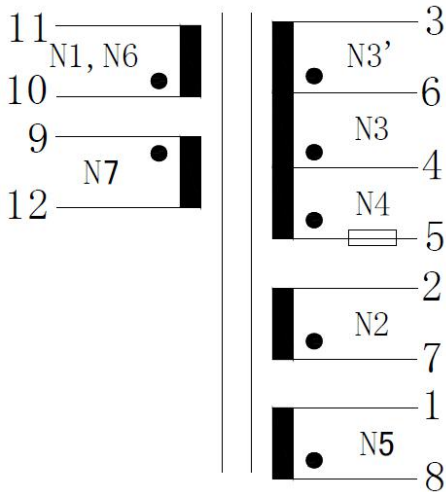

3. WINDING:

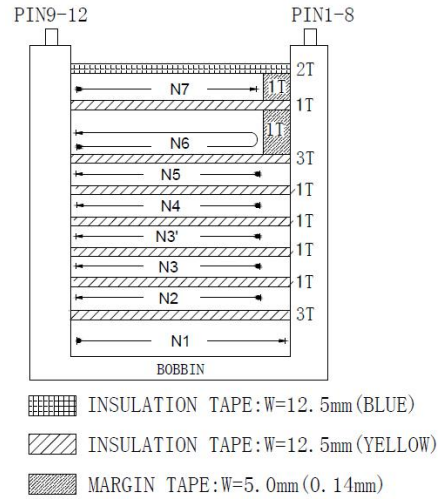

4. WINDING TABLE:

Winding NO.	Margin Tape	PIN	Wire & Wire Copper	Turns	Winding Type	Tape Layer	Tube
N1	0	10~11			Compact	3.0	0
N2	0	7~2			Dispersed	1.0	0
N3	0	4~6			Dispersed	1.0	0
N3'	0	6~3			Dispersed	1.0	0
N4	0	5~4			Dispersed	1.0	F ≈ 10mm
N5	0	8~1			Dispersed	3.0	0
N6	5.0	10~11			Compact	1.0	0
N7	5.0	9~12			Dispersed	2.0	0

NOTE:

- 1. Products should be vacuum varnish
 - *VARNISH RATIO: 1:1
 - *VACUUM TIME: 15~20minutes
 - *BAKED TEMPERATURE : 120°C±10°C , 1~1.5hours

LEAD FREE

	DESCRIPTION	TRANSFORMER	
	Customer P/N		
	FERRIWO P/N	FWPTEF20H421K-1	
SPEC. NO.	PS-1001-058	PREPARED	APPROVED

SPECIFICATION

5. ELECTRONICAL CHARACTERISTIC:

TEST CONDITION : TEMPERATURE AT 25 °C
HUMIDITY AT 65 ±5% RH

TEST ITEM	TEST CONDITION	RESULT
INDUCTANCE CH-3250	@10.0KHz,0.3V (11~10)	420uH ± 10%
LEAKAGE INDUCTANCE CH-3250	@100.0KHz,0.1V (11~10)short(9~12) (11~10)short(4~5) (11~10)short(6~4) (11~10)short(3~6) (11~10)short(2~7) (11~10)short(1~8)	55uH MAX 45uH MAX 30uH MAX 40uH MAX 35uH MAX 35uH MAX
D.C.R TH2513A	@at25°C (10~11) (9~12) (8~1) (7~2) (6~3) (4~6) (5~4)	1.6Ω MAX 390mΩ MAX 325mΩ MAX 20mΩ MAX 365mΩ MAX 365mΩ MAX 220mΩ MAX
HI-POT TEST CH-9052	@ 1mA 2SEC (AC)	P<->S 3.0 KV; P、S<-> CORE 1.5KV;

LEAD FREE

	DESCRIPTION	TRANSFORMER	
	Customer P/N		
	FERRIWO P/N	FWPTEF20H421K-1	
SPEC. NO.	PS-1001-058	PREPARED	APPROVED

SPECIFICATION

6. MATERIAL LIST :

ITEM		MATERIAL	SUPPLIER OR MANUFACTURER	TEMPRATING
1	CORE	FW40 OR EQUIVALENT	HAINING FERRIWO ELECTRONICS CO., LTD.	
2	BOBBIN	PHENOLIC OR EQUIVALENT	SUMITOMO BAKELITE CO., LTD. UL NO E41429	150 °C
3	WIRE	2UEW	PACIFIC ELECTRIC WIRE&CABLE(SHENZHEN) CO. LTD UL NO E2114423	155 °C
4	TRIPLE WIRE	TRIPLE. INSULATION. WIRE TRW(B)	GREAT LEOFLON INDUSTRIAL CO.,LTD UL NO E211989	130 °C
5	TAPE	CT280	YAHUA STICKING TAPE CO.,LTD UL NO E165111	130 °C
6	MARGIN TAPE	WF-2902	YAHUA STICKING TAPE CO.,LTD UL NO E324093	130 °C
7	VARNISH	T-4260(A)	SUZHOU TAIHU ELECTRIC ADVANCED MATERIAL CO, LTD UL NO E228349	130 °C
8	FLUX	TF9100	LINAN GUITONG CHEMICAL TECHNICAL CO.,LTD	
9	TIN	Sn99.3Cu0.7	HAINING ZHUCHANG METAL FOIL CO;LTD	
10	TUBE	TEFLON TUBE	GREAT HOLDING INDUSTRIAL CO.,LTD UL NO E156256	200 °C

LEAD FREE



DESCRIPTION

TRANSFORMER

Customer P/N

FERRIWO P/N

FWPTEF20H421K-1

SPEC. NO.

PS-1001-058

PREPARED

APPROVED