

SPECIFICATION

1. PHYSICAL DIMENSION(UNIT: m/m):

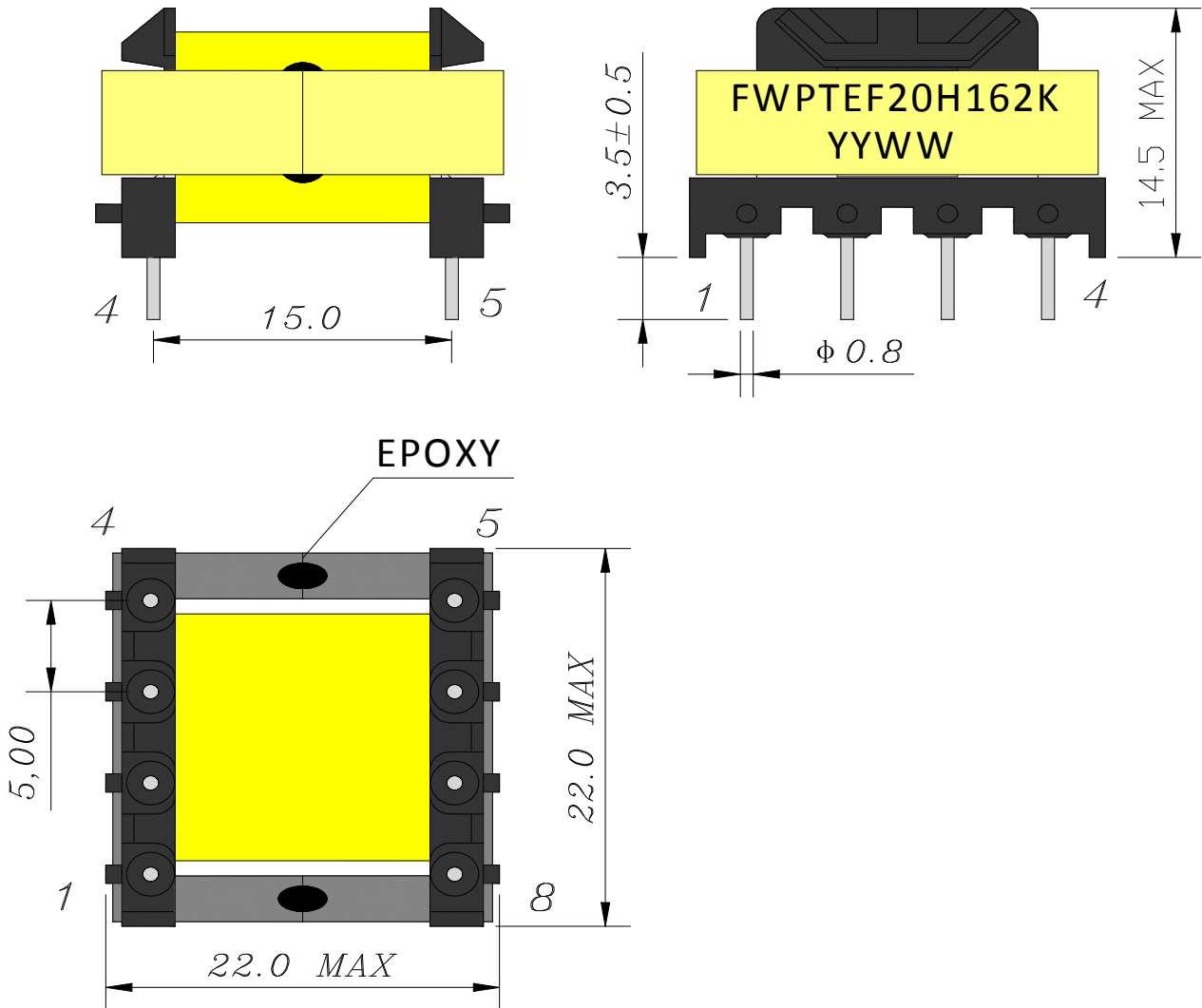

※DIMENSIONS WITHOUT TOLERANCE ARE APPROX
 ※DIMENSION DOES NOT INCLUDE SOLDER USED ONCOILS

LEAD FREE

DIM	A	B	C	D	E	F	G	H				
SPEC												
							DESCRIPTION			TRANSFORMER		
							Customer P/N			EF20		
							FERRIWO P/N			FWPT20H162K		
SPEC. NO.	PS-1001-133				PREPARED			APPROVED				

SPECIFICATION

2.WINDING TABLE:

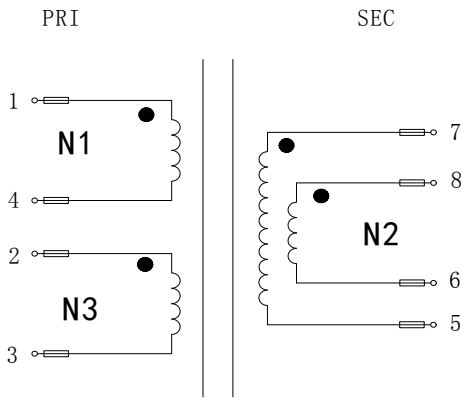

3.WINDING:

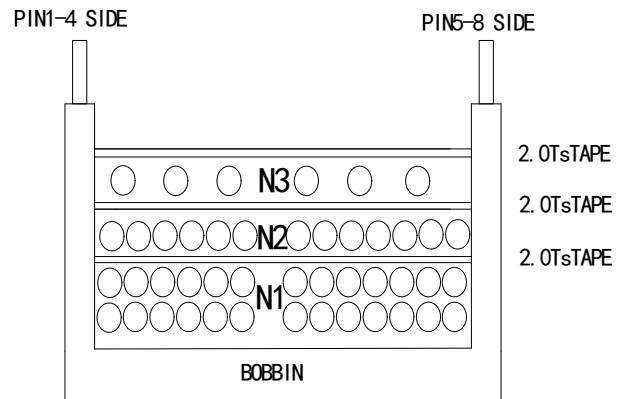

4.WINDING TABLE:

Winding NO.	Margin Tape	PIN	Wire & Wire Copper	Turns	Winding Type	Tape Layer	Tube
N1	0	1~4			Compact	2	F=S≈10mm
N2	0	7~5			Compact	2	F=S≈10mm
		8~6					
N3	0	2~3			Dispersed	2	F=S≈10mm

NOTE:

- Products should be vacuum varnish
 - *VARNISH RATIO: 1:1
 - *VACUUM TIME: 15~20minutes
 - *BAKED TEMPERATURE : 120°C±10°C, 1~1.5hours

LEAD FREE

DESCRIPTION	TRANSFORMER
Customer P/N	EF20
FERRIWO P/N	FWPTEF20H162K

SPEC. NO.

PS-1001-133

PREPARED



APPROVED





SPECIFICATION

5. ELECTRONICAL CHARACTERISTIC:

TEST CONDITION : TEMPERATURE AT 25°C
HUMIDITY AT 65 ±5% RH

TEST ITEM	TEST CONDITION	RESULT
INDUCTANCE CH-3250	@1.0KHz,1.0V (1~4) (7~5)=(8~6) (2~3)	1.62mH±10% 16.7uH±10% 10.3uH±10%
D.C.R CH-502	(1~4) (7~5)=(8~6) (2~3)	TBD
HI-POT TEST CH-9052	@ 2mA 3SEC	P<->S 3.0 KV; COIL<->CORE 1.0 KV;

LEAD FREE

	DESCRIPTION	TRANSFORMER			
	Customer P/N	EF20			
	FERRIWO P/N	FWPTEF20H162K			
SPEC. NO.	PS-1001-133	PREPARED		APPROVED	

SPECIFICATION

6. MATERIAL LIST :

ITEM		MATERIAL	SUPPLIER OR MANUFACTURER	TEMPRATING
1	CORE	FW95 OR EQUIVALENT	HAINING FERRIWO ELECTRONICS CO., LTD.	
2	BOBBIN	PHENOLIC OR EQUIVALENT	SUMITOMO BAKELITE CO., LTD. UL NO E41429	150℃
3	WIRE	2UEW	PACIFIC ELECTRIC WIRE&CABLE(SHENZHEN) CO. LTD UL NO E84081	155℃
4	TRIPLE WIRE	TRIPLE. INSULATION. WIRE TRW(B)	GREAT LEOFロン INDUSTRIAL CO.,LTD UL NO E211989	130℃
5	TAPE	CT280	YAHUA STICKING TAPE CO.,LTD UL NO E165111	130℃
6	EPOXY	E-500 (Black)	SUZHOU EATTO ELECTRONIC MATERIAL CO.,LTD	130℃
7	TUBE	TEFLON TUBE	GREAT HOLDING INDUSTRIAL CO.,LTD UL NO E156256	200℃
8	FLUX	TF9100	LINAN GUITONG CHEMICAL TECHNICAL CO.,LTD	
9	VARNISH	T-4260A	WUJIANG TAIHU INSULATING MATERIAL CO., LTD UL NO E228349	130℃
10	TIN	Sn99.3Cu0.7	HAINING ZHUCHANG METAL FOIL CO;LTD	

LEAD FREE



DESCRIPTION

TRANSFORMER

Customer P/N

EF20

FERRIWO P/N

FWPTEF20H162K

SPEC. NO.

PS-1001-133

PREPARED



APPROVED

