

# SPECIFICATION

1. PHYSICAL DIMENSION(UNIT: m/m):

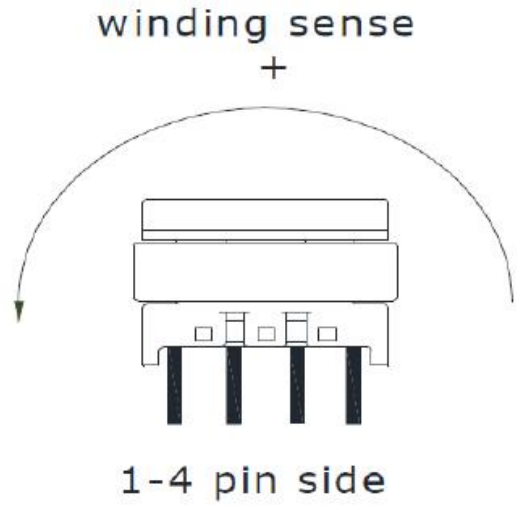
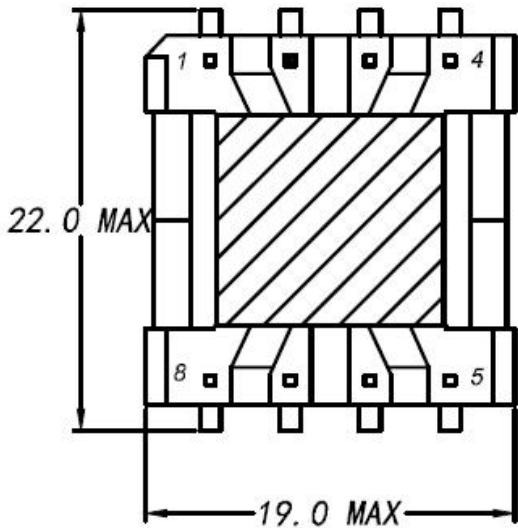
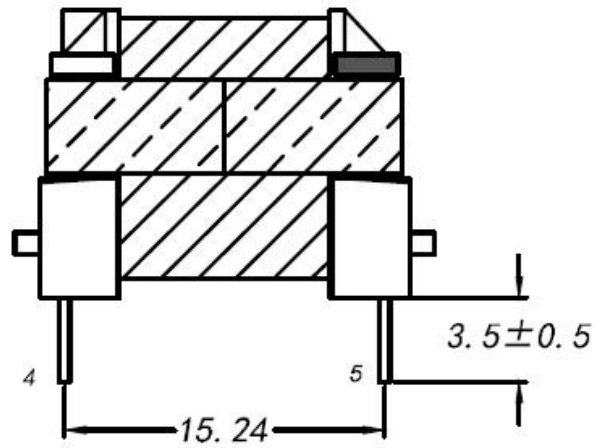
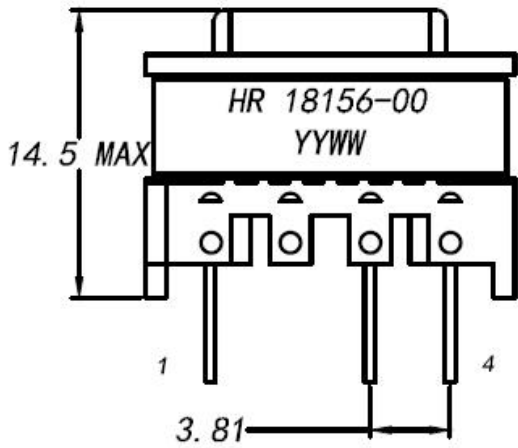

**NOTE: PIN2 CUT OFF**

- ※DIMENSIONS WITHOUT TOLERANCE ARE APPROX
- ※DIMENSION DOES NOT INCLUDE SOLDER USED ONCOILS

**LEAD FREE**

DIM	A	B	C	D	E	F	G	H	I	J	K	L
SPEC												
							DESCRIPTION			TRANSFORMER		
							Customer P/N					
							FERRIWO P/N			FWPTEF16H361K		
SPEC. NO.	PS-1001-064				PREPARED			APPROVED				

# SPECIFICATION

## 2. WINDING TABLE:

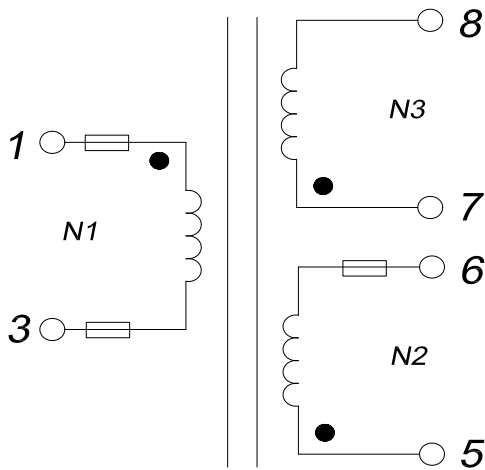

## 3. WINDING:

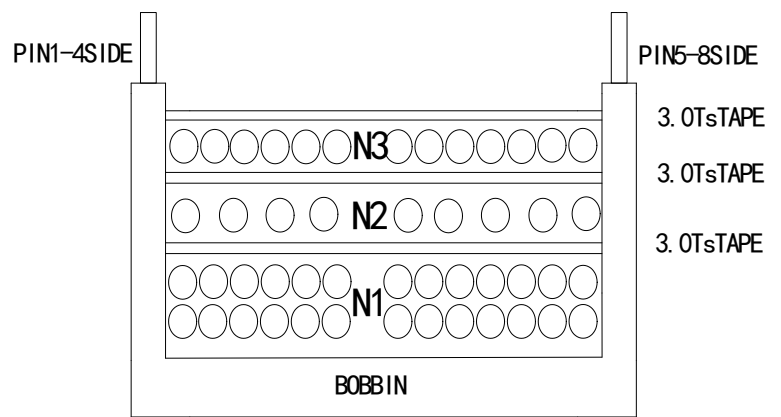

## 4. WINDING TABLE:

Winding NO.	Margin Tape	PIN	Wire & Wire Copper	Turns	Winding Type	Tape Layer	Tube
N1	0	1~3			Compact	3.0	F=S≈10mm
N2	0	5~6			Compact at PIN5-8 side	3.0	S≈10mm
N3	0	7~8			Compact	3.0	0

### NOTE:

- Products should be vacuum varnish
  - \*VARNISH RATIO: 1:1
  - \*VACUUM TIME: 15~20minutes
  - \*BAKED TEMPERATURE : 120°C±10°C, 1~1.5hours

**LEAD FREE**

DESCRIPTION	TRANSFORMER
Customer P/N	
FERRIWO P/N	FWPTEF16H361K

SPEC. NO.	PS-1001-064	PREPARED		APPROVED	
-----------	-------------	----------	--	----------	--



# SPECIFICATION

**5. ELECTRONICAL CHARACTERISTIC:**

TEST CONDITION : TEMPERATURE AT 25°C  
HUMIDITY AT 65 ±5% RH

TEST ITEM	TEST CONDITION	RESULT
INDUCTANCE CH-3250	@1.0KHz,0.25V (1~3) (5~6) (7~8)	360uH ± 10% 31uH ± 10% 194uH ± 10%
LEAKAGE INDUCTANCE CH-3250	@100.0KHz,0.25V short(pin5,6,7,8)	7.5uH MAX
D.C.R TH2513A	@at25°C (1~3) (5~6) (7~8)	235mΩ ref. 84mΩ ref. 335mΩ ref.
HI-POT TEST CH-9052	@ 2mA 2SEC (AC)	P<->S<-> CORE      1.5 KV; P、 S<-> CORE      0.5 KV;

**LEAD FREE**

	DESCRIPTION	TRANSFORMER			
	Customer P/N				
	FERRIWO P/N	FWPTEF16H361K			
SPEC. NO.	PS-1001-064	PREPARED		APPROVED	

# SPECIFICATION

## 6. MATERIAL LIST :

ITEM	MATERIAL	SUPPLIER OR MANUFACTURER	TEMPRATING	
1	CORE	FW40 OR EQUIVALENT	HAINING FERRIWO ELECTRONICS CO., LTD.	
2	BOBBIN	PHENOLIC OR EQUIVALENT	SUMITOMO BAKELITE CO., LTD. UL NO E41429	150°C
3	WIRE	2UEW	PACIFIC ELECTRIC WIRE&CABLE(SHENZHEN) CO. LTD UL NO E2114423	155°C
4	TAPE	CT280	YAHUA STICKING TAPE CO.,LTD UL NO E165111	130°C
5	VARNISH	T-4260(A)	SUZHOU TAIHU ELECTRIC ADVANCED MATERIAL CO, LTD UL NO E228349	130°C
6	FLUX	TF9100	LINAN GUITONG CHEMICAL TECHNICAL CO.,LTD	
7	TIN	Sn99.3Cu0.7	HAINING ZHUCHANG METAL FOIL CO;LTD	
8	TUBE	TEFLON TUBE	GREAT HOLDING INDUSTRIAL CO.,LTD UL NO E156256	200°C

**LEAD FREE**



DESCRIPTION	TRANSFORMER
Customer P/N	
FERRIWO P/N	FWPTEF16H361K

SPEC. NO.

PS-1001-064

PREPARED



APPROVED

