

1. PHYSICAL DIMENSION(UNIT: m/m):

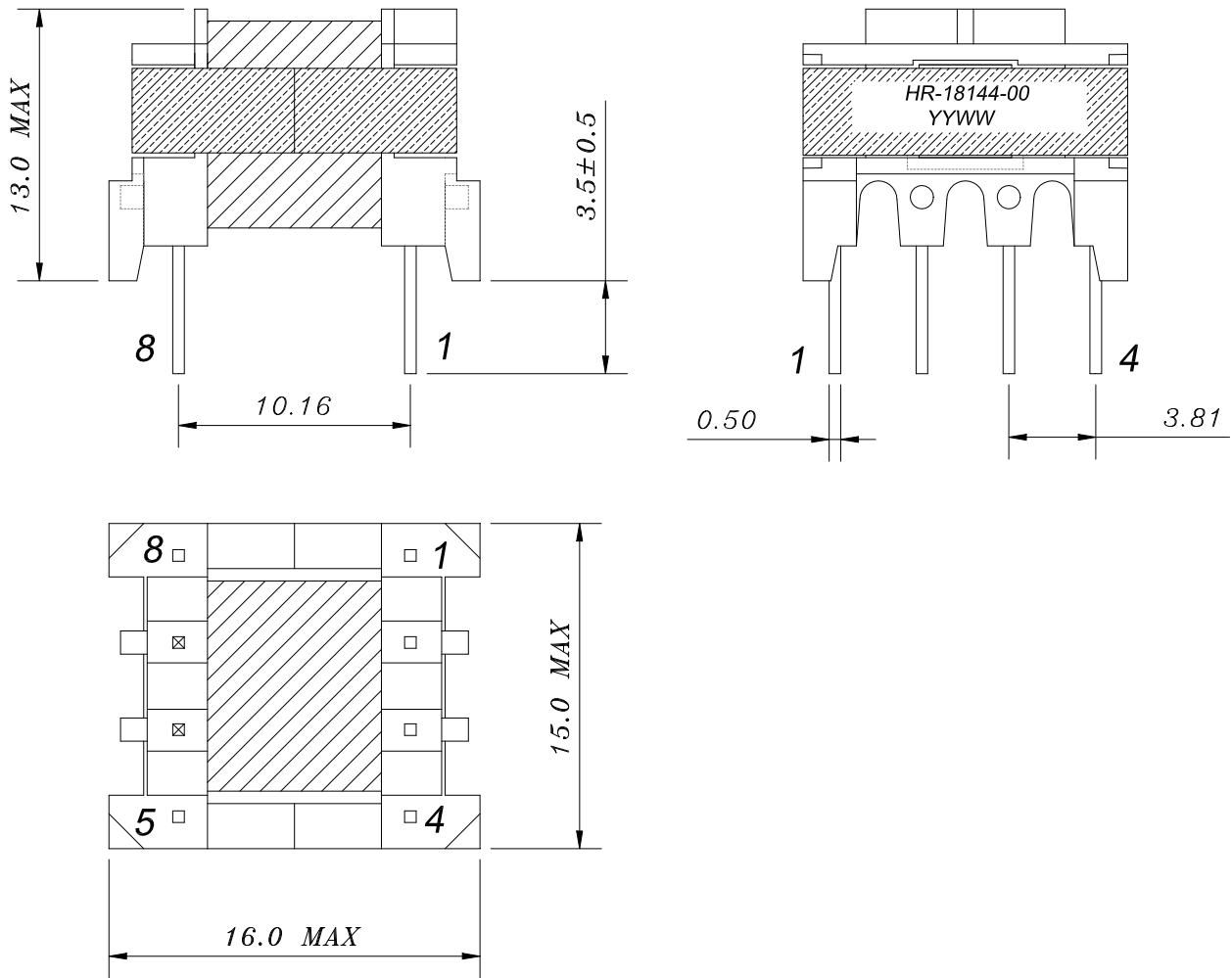

※ DIMENSIONS WITHOUT TOLERANCE ARE APPROX
 ※ DIMENSION DOES NOT INCLUDE SOLDER USED ON COILS

LEAD FREE

* PIN6, 7 CUT OFF.

DIM	A	B	C	D	E	F	G	H				
SPEC												
						DESCRIPTION			TRANSFORMER			
						Customer P/N						
						FERRIWO P/N			FWPTEF12.6H122K			
SPEC. NO.	PS-1001-059				PREPARED			APPROVED				

2.WINDING TABLE:

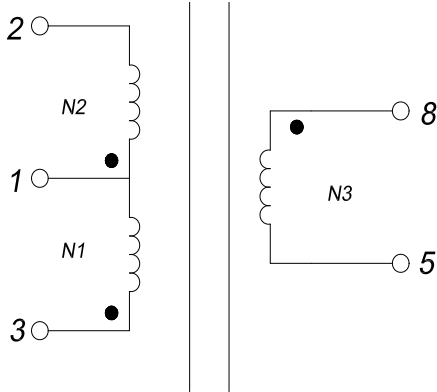

3.WINDING:

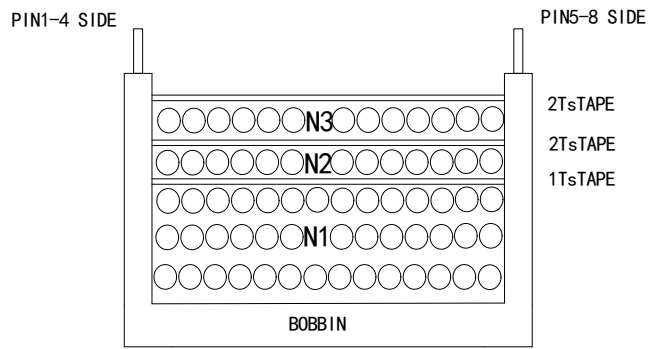

4.WINDING TABLE:

Winding NO.	Margin Tape	PIN	Wire &Wire Copper	Turns	Winding Type	Tape Layer	Tube
N1	0	3~1			Compact	1	0
N2	0	1~2			Compact	2	0
N3	0	8~5			Compact	2	0

NOTE:

- Products should be vacuum varnish
 - *VARNISH RATIO: 1:1
 - *VACUUM TIME: 15~20minutes
 - *BAKED TEMPERATURE : 120°C±10°C, 1~1.5hours
- Pin 1 should be outside when the bobbin insert into the winding machine.

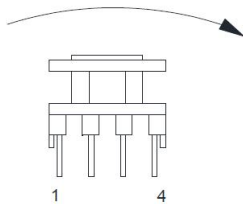

WINDING SENSE (-)



LEAD FREE



DESCRIPTION	TRANSFORMER
Customer P/N	
FERRIWO P/N	FWPTEF12.6H122K

SPEC. NO.	PS-1001-059	PREPARED		APPROVED	
-----------	-------------	----------	--	----------	---



SPECIFICATION

5. ELECTRONICAL CHARACTERISTIC:

**TEST CONDITION : TEMPERATURE AT 25 °C
HUMIDITY AT 65 ±5% RH**

TEST ITEM	TEST CONDITION	RESULT
INDUCTANCE CH-3250	@1.0KHz,0.25V (3~1) (3~2) (8~5)	1.25mH±10% 1.495mH±10% 56.4uH±10%
LEAKAGE INDUCTANCE CH-3250	@100KHz,0.25V (1~2)	50.0μH MAX. SHORT OTHER PINS
D.C.R CH-502	(3~1) (3~2) (8~5)	1.43Ω±15% 1.51Ω±15% 95mΩ±15%
HI-POT TEST CH-9052	@ 0.5mA 3.0SEC (AC)	P<->S 3.0 KV; P、S<->CORE 1.0KV;

LEAD FREE

	DESCRIPTION	TRANSFORMER			
	Customer P/N				
	FERRIWO P/N	FWPTEF12.6H122K			
SPEC. NO.	PS-1001-059	PREPARED		APPROVED	

SPECIFICATION

6. MATERIAL LIST :

ITEM	MATERIAL	SUPPLIER OR MANUFACTURER	TEMPRATING	
1	CORE	FW40 OR EQUIVALENT	HAINING FERRIWO ELECTRONICS CO., LTD.	
2	BOBBIN	PHENOLIC OR EQUIVALENT	SUMITOMO BAKELITE CO., LTD. UL NO E41429	150 °C
3	WIRE	2UEW-F	PACIFIC ELECTRIC WIRE&CABLE(SHENZHEN) CO. LTD UL NO E84081	155 °C
4	TRIPLE WIRE	TRIPLE. INSULATION. WIRE TRW(B)	GREAT LEOFLON INDUSTRIAL CO.,LTD UL NO E211989	130 °C
5	TAPE	CT280	YAHUA STICKING TAPE CO.,LTD UL NO E165111	130 °C
6	VARNISH	T-4260A	WUJIANG TAIHU INSULATING MATERIAL CO., LTD UL NO E228349	130 °C
7	FLUX	TF9100	LINAN GUITONG CHEMICAL TECHNICAL CO.,LTD	
8	TIN	Sn99.3Cu0.7	HAINING ZHUCHANG METAL FOIL CO;LTD	

LEAD FREE



DESCRIPTION

TRANSFORMER

Customer P/N

FERRIWO P/N

FWPTEF12.6H122K

SPEC. NO.

PS-1001-059

PREPARED



APPROVED

