

SPECIFICATION

1. PHYSICAL DIMENSION(UNIT: m/m):

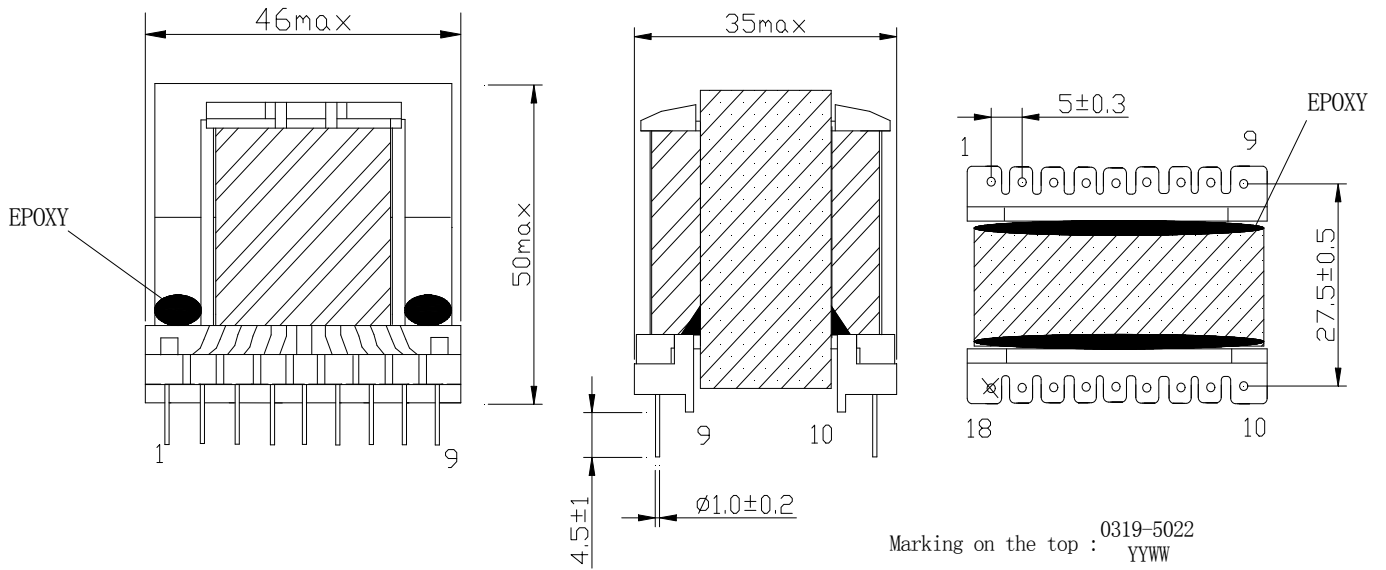

- ※ DIMENSIONS WITHOUT TOLERANCE ARE APPROX
- ※ DIMENSION DOES NOT INCLUDE SOLDER USED ON COILS

LEAD FREE

*PIN18 CUT OFF.

DIM	A	B	C	D	L	P1	P2										
SPEC																	
						DESCRIPTION		TRANSFORMER									
						Customer P/N											
						FERRIWO P/N		FWPTEE42V461J									
SPEC. NO.	PS-1001-042				PREPARED			APPROVED									

SPECIFICATION

2.WINDING TABLE:

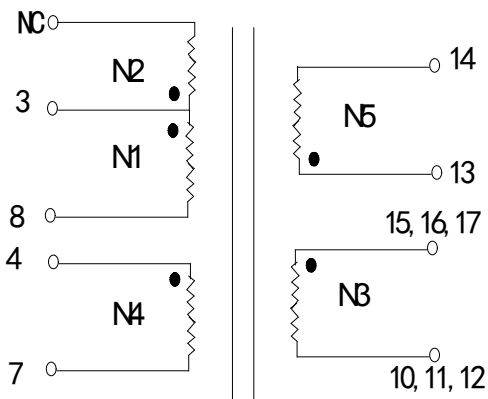

3.WINDING:

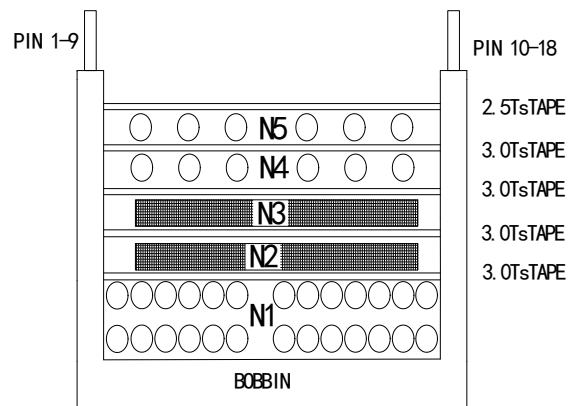

4.WINDING TABLE:

Winding NO.	Margin Tape	PIN	Wire &Wire Copper	Turns	Winding Type	Tape Layer	Tube
N1	0	3~8			Compact	3.0	0
N2	0	3~NC			Compact	3.0	0
N3	0	15,16,17~ 10,11,12			Compact	3.0	0
N4	0	4~7			Dispersed	3.0	0
N5	0	13~14			Dispersed	2.5	0

NOTE:

- Products should be vacuum varnish
 - *VARNISH RATIO: 1:2
 - *VACUUM TIME: 15~20minutes
 - *BAKED TEMPERATURE : 120°C±10°C, 1~1.5hours

LEAD FREE

	DESCRIPTION	TRANSFORMER			
	Customer P/N				
	FERRIWO P/N	FWPTEE42V461J			
SPEC. NO.	PS-1001-042	PREPARED		APPROVED	

SPECIFICATION

4/5

5. ELECTRONICAL CHARACTERISTIC:

TEST CONDITION : TEMPERATURE AT 25 °C

HUMIDITY AT 65 ±5% RH

TEST ITEM	TEST CONDITION	RESULT
INDUCTANCE CH-3250	@10.0KHz,1.0V (3~8)	460uH ± 7.5%
D.C.R CH-502	(3~8)	200mΩ MAX.
HI-POT TEST CH-9052	@ 2mA 2SEC (AC)	P<->S 1.65 KV; COIL<-> CORE 1.65KV;

LEAD FREE



DESCRIPTION

TRANSFORMER

Customer P/N

FERRIWO P/N

FWPTEE42V461J

SPEC. NO.

PS-1001-042

PREPARED



APPROVED



SPECIFICATION

6. MATERIAL LIST :

ITEM	MATERIAL	SUPPLIER OR MANUFACTURER	TEMPRATING
1	CORE FW40 OR EQUIVALENT	HAINING FERRIWO ELECTRONICS CO., LTD.	
2	BOBBIN PHENOLIC OR EQUIVALENT	SUMITOMO BAKELITE CO., LTD. UL NO E41429	150°C
3	WIRE 2UEW	PACIFIC ELECTRIC WIRE&CABLE(SHENZHEN) CO. LTD UL NO E2114423	155°C
4	COPPER FOIL 0.1t*22.0mm 0.05t*22.0mm	YAHUA STICKING TAPE CO.,LTD	
5	TAPE CT280	YAHUA STICKING TAPE CO.,LTD UL NO E165111	130°C
6	VARNISH T-4260(A)	SUZHOU TAIHU ELECTRIC ADVANCED MATERIAL CO, LTD UL NO E228349	130°C
7	FLUX TF9100	LINAN GUITONG CHEMICAL TECHNICAL CO.,LTD	
8	TIN Sn99.3Cu0.7	HAINING ZHUCHANG METAL FOIL CO;LTD	

LEAD FREE



DESCRIPTION

TRANSFORMER

Customer P/N

FERRIWO P/N

FWPTEE42V461J

SPEC. NO.

PS-1001-042

PREPARED



APPROVED

