

# SPECIFICATION

1. PHYSICAL DIMENSION(UNIT: m/m):

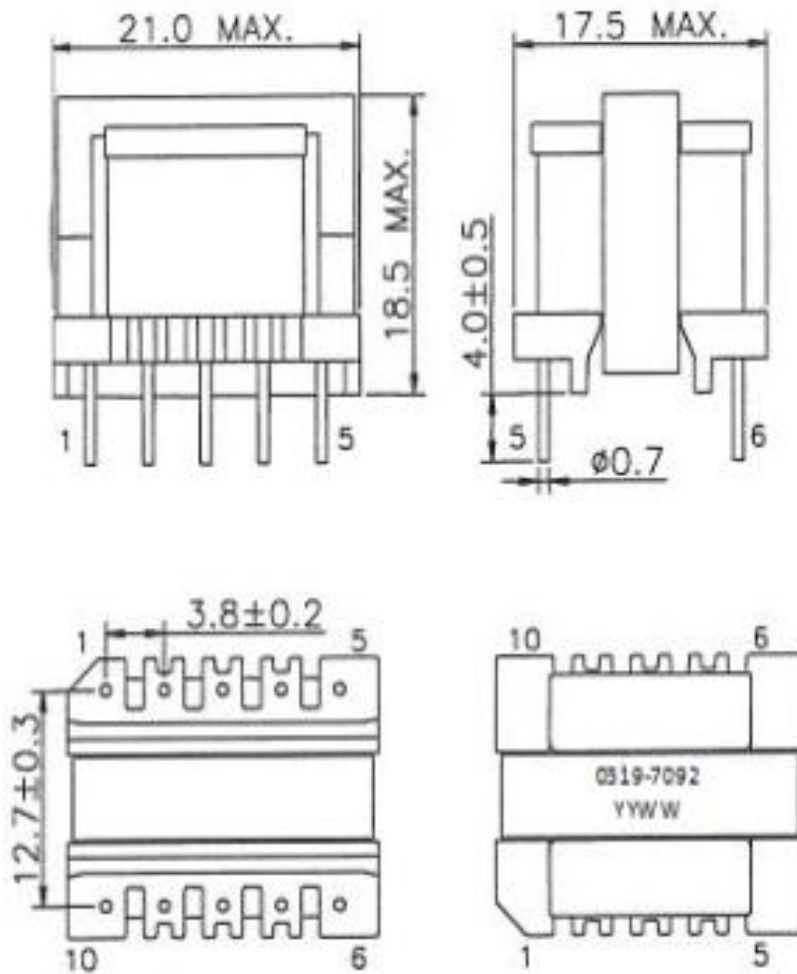

- ※ DIMENSIONS WITHOUT TOLERANCE ARE APPROX
- ※ DIMENSION DOES NOT INCLUDE SOLDER USED ON COILS

**LEAD FREE**

DIM	A	B	C	D	L	P1	P2										
SPEC																	
						DESCRIPTION		TRANSFORMER									
						Customer P/N											
						FERRIWO P/N		FWPTEE19V302K									
SPEC. NO.	PS-1001-041				PREPARED			APPROVED									

# SPECIFICATION

## 2.WINDING TABLE:

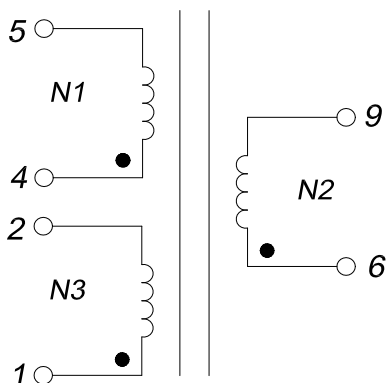

## 3.WINDING:

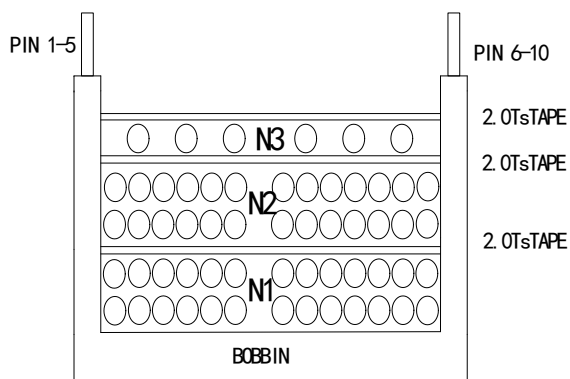

## 4.WINDING TABLE:

Winding NO.	Margin Tape	PIN	Wire &Wire Copper	Turns	Winding Type	Tape Layer	Tube
N1	0	4~5			Compact	2.0	0
N2	0	6~9			Compact	2.0	0
N3	0	1~2			Dispersed	2.0	0

### NOTE:

- Products should be vacuum varnish
  - \*VARNISH RATIO: 1:2
  - \*VACUUM TIME: 15~20minutes
  - \*BAKED TEMPERATURE : 120°C±10°C , 1~1.5hours

**LEAD FREE**

DESCRIPTION	TRANSFORMER
Customer P/N	
FERRIWO P/N	FWPTEE19V302K

SPEC. NO.	PS-1001-041	PREPARED		APPROVED	
-----------	-------------	----------	--	----------	--

# SPECIFICATION

## 5. ELECTRONICAL CHARACTERISTIC:

TEST CONDITION : TEMPERATURE AT 25 °C

HUMIDITY AT 65 ±5% RH

TEST ITEM	TEST CONDITION	RESULT
INDUCTANCE CH-3250	@1.0KHz,1.0V (4~5)	3.0mH ± 10%
HI-POT TEST CH-9052	@ 2mA 2SEC (AC)	P<->S 1.6 KV; COIL<-> CORE 1.6KV;

**LEAD FREE**



DESCRIPTION

TRANSFORMER

Customer P/N

FERRIWO P/N

FWPTEE19V302K

SPEC. NO.

PS-1001-041

PREPARED



APPROVED



# SPECIFICATION

## 6. MATERIAL LIST :

ITEM	MATERIAL	SUPPLIER OR MANUFACTURER	TEMPRATING	
1	CORE	FW40 OR EQUIVALENT	HAINING FERRIWO ELECTRONICS CO., LTD.	
2	BOBBIN	PHENOLIC OR EQUIVALENT	SUMITOMO BAKELITE CO., LTD. UL NO E41429	150 °C
3	WIRE	UEW	PACIFIC ELECTRIC WIRE&CABLE(SHENZHEN) CO. LTD UL NO E84081	130 °C
4	TAPE	CT280	YAHUA STICKING TAPE CO.,LTD UL NO E165111	130 °C
5	VARNISH	T-4260(A)	SUZHOU TAIHU ELECTRIC ADVANCED MATERIAL CO, LTD UL NO E228349	130 °C
6	FLUX	TF9100	LINAN GUITONG CHEMICAL TECHNICAL CO.,LTD	
7	TIN	Sn99.3Cu0.7	HAINING ZHUCHANG METAL FOIL CO;LTD	

**LEAD FREE**



DESCRIPTION

TRANSFORMER

Customer P/N

FERRIWO P/N

FWPTEE19V302K

SPEC. NO.

PS-1001-041

PREPARED



APPROVED

